



**Harris
Broadcast**

Deliver the moment.

DAB+ ECONOMICAL ADVANTAGES

A comparison to FM

Gino Mils

Regional Sales Director – Africa

ABOUT HARRIS

Harris is the largest transmitter manufacturer world wide

**DTV & DAB
Transmitter
VHF, UHF**



**FM, DRM+, HD Radio
Transmitter
VHF**



**AM, DRM, HD Radio
Transmitter
Medium Wave**



ABOUT HARRIS

Harris is Market leader in supply of Digital Radio transmitters

- More than 2.000 Harris DAB Transmitter deliveries
- Present in all Markets
- Latest big deals:
 - 2012/13 Norway 750 Tx
 - 2013 Netherlands 35 Tx

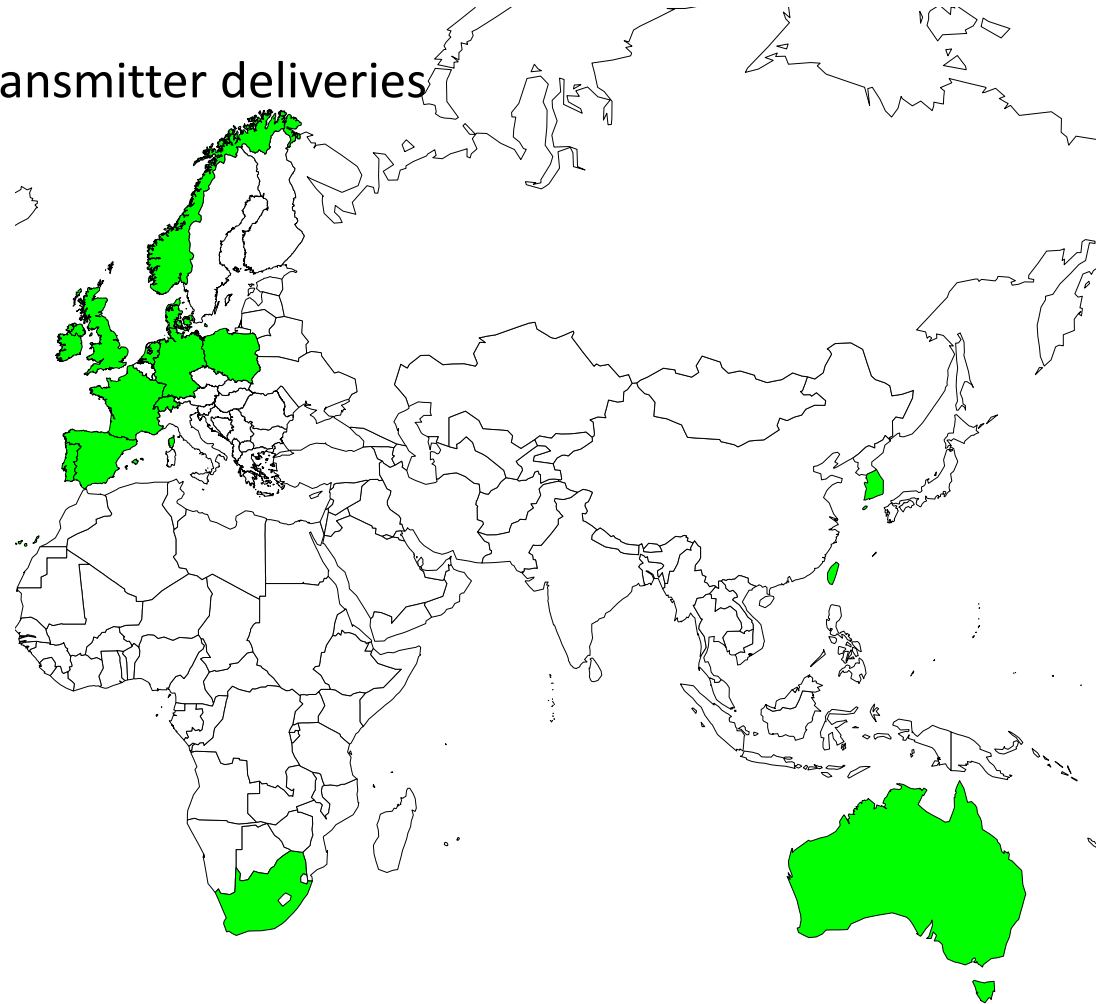

ECONOMICAL ADVANTAGES OF DAB+ INTRODUCTION

Main cost factors of Radio operation

□ Equipment

Capital Expenses (CAPEX)

□ Distribution

□ Energy

□ Cooling

□ Floor space

□ Service & maintenance

□ License fee

Operational Expenses (OPEX)

□ Simulcast period, operation of analog and digital Radio in parallel

INTRODUCTION

FM - DAB

DIFFERENCES BETWEEN DAB+ AND FM TRANSMISSION

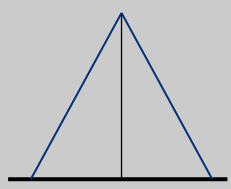
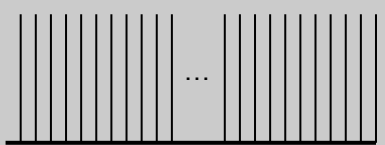

FM	Parameter	DAB+
87,5 MHz – 108 MHz	Frequency	174 MHz – 240 MHz
Peak	Tx Power	RMS
200 kHz	Channel	1,5 MHz
1 per channel	Programs	up to 25 per channel
RDS 1,2 kBit/s	Data	Flexible data rates for Program Associated and Non Program Associated Data rates
Analoge L/R, Stereo Composite, AES IP (Audio over IP)	Input	Digital ETI 2.048 Mbit/s EDI (ETI over IP)
Single Carrier FM	Modulation	Multi Carrier (1536) OFDM, type DQPSK
 <p>-100 kHz +100 kHz</p>		 <p>-768 kHz +768 kHz</p>

DAB FAMILY OF STANDARDS - NO DIFFERENCE FOR THE TRANSMITTER

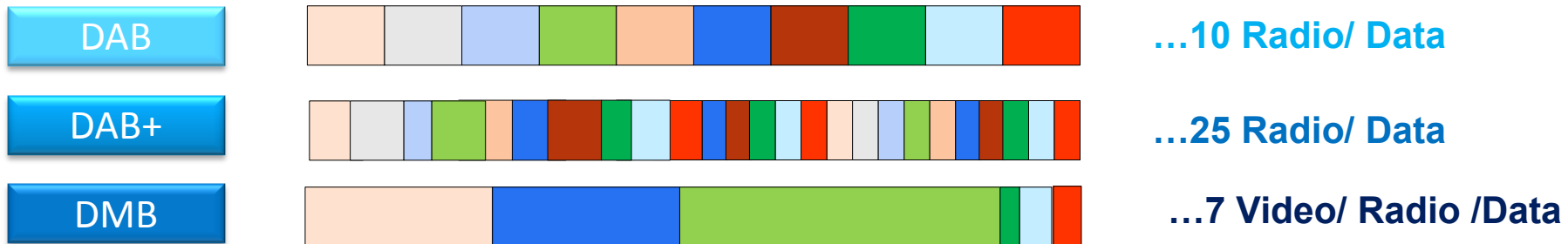

- Net data rate of approx. 1.2MBit/s
- Each DAB transmitter can operate DAB, DAB+, DMB without changes
- There is **no** difference in Hardware or Software for the transmitter !

- The differences are managed by the Play-Out equipment
 - audio encoding
 - video encoding (DMB)
 - data server
 - error protection

DISTRIBUTION EFFORT STUDIO-TRANSMITTER

RADIO NETWORK INFRASTRUCTURE

- FM Radio** - one Radio program to one transmitter
- each Radio program needs a different frequency

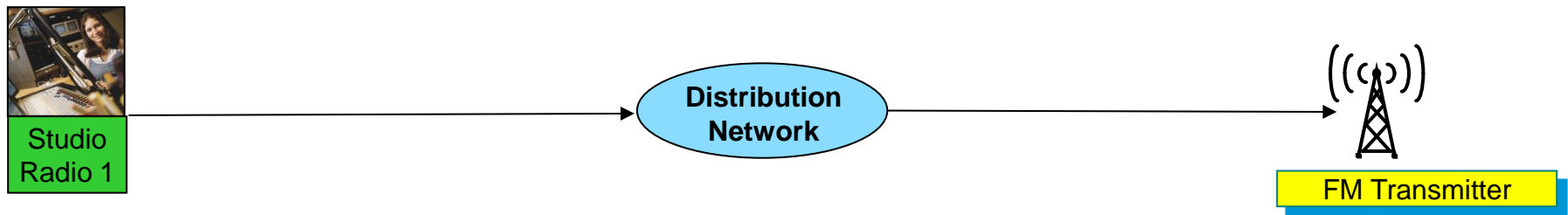

- DAB+ Radio** - up to 25 Radio programs to one transmitter
- reduced infrastructure
- frequency efficient

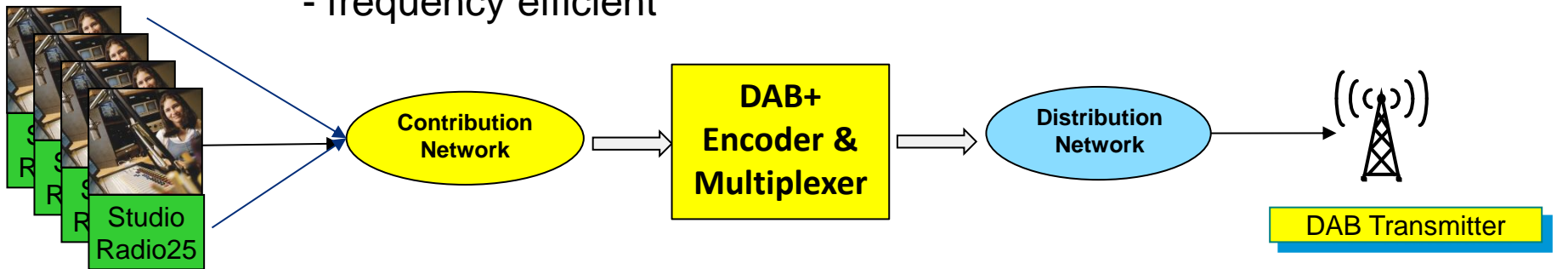

SPECTRUM EFFICIENCY

Multiple transmitter might be necessary to cover large areas

FM: each transmitter with a different frequency (VHF Band II) for only one program

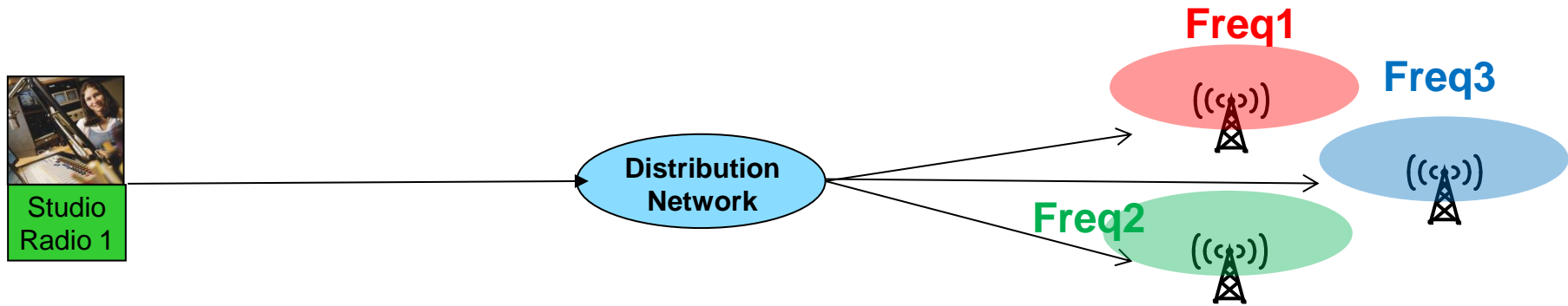

Single Frequency Network (SFN) to cover a larger area with DAB+ (VHF Band III) up to 25 Radio Programs in one channel

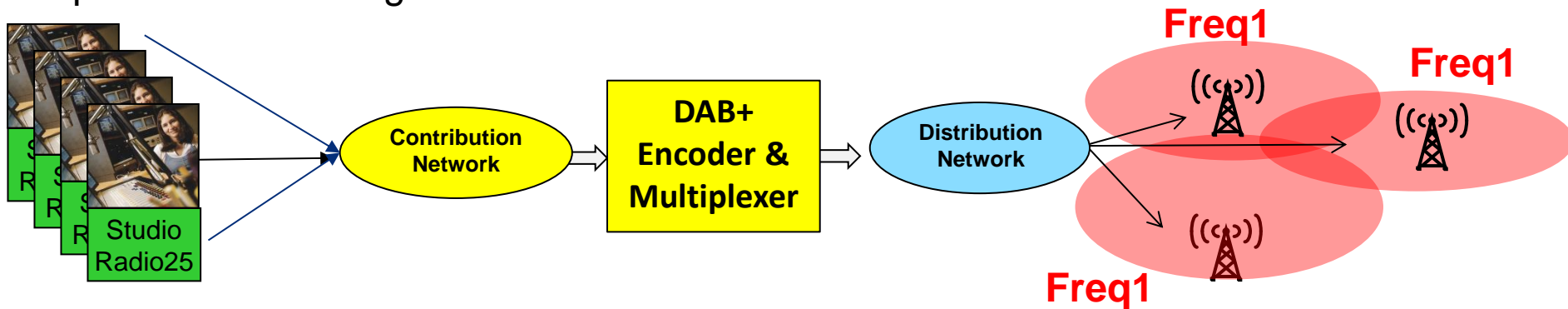

**THE FOLLOWING COMPARISONS ARE
MADE FOR A NETWORK OF 15 RADIO
PROGRAMS WITH SAME COVERAGE
EACH**

EQUIPMENT COSTS

TRANSMITTER INVESTMENT COSTS DAB+ VS. FM

EXAMPLE: 15 RADIO PROGRAMS SAME COVERAGE

Transmitter	FM	DAB
Power	10 kW peak	2,5 kW rms
Price per unit	50.000 USD	120.000 USD
for 15 Radio programs	15 transmitter	1 transmitter
Price of 15 Transmitter	750.000 USD	120.000 USD

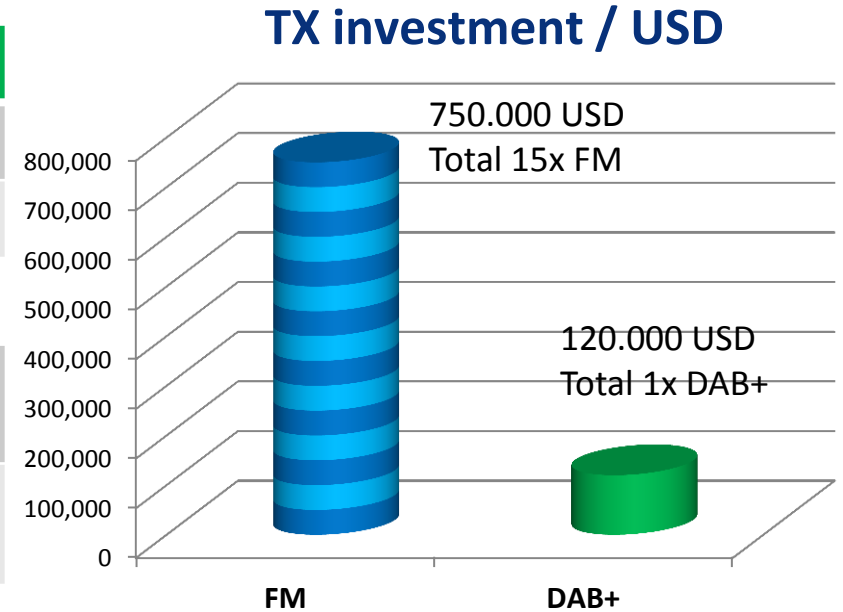

6 x lower transmitter investment costs with DAB+ compared to FM for the example 15 Radio Programs

ENERGY COSTS

ENERGY CONSUMPTION TRANSMITTER DAB+ VS. FM

EXAMPLE: 15 RADIO PROGRAMS SAME COVERAGE

	FM	DAB
TX RF Power	10 kW peak	2,5 kW rms
Efficiency 2012	72%	30%
Energy per transmitter	13,9 kW	8,3 kW

Transmitter for 15 programs	15	1
Energy for 15 Programs	208,3 kW	8,3 kW

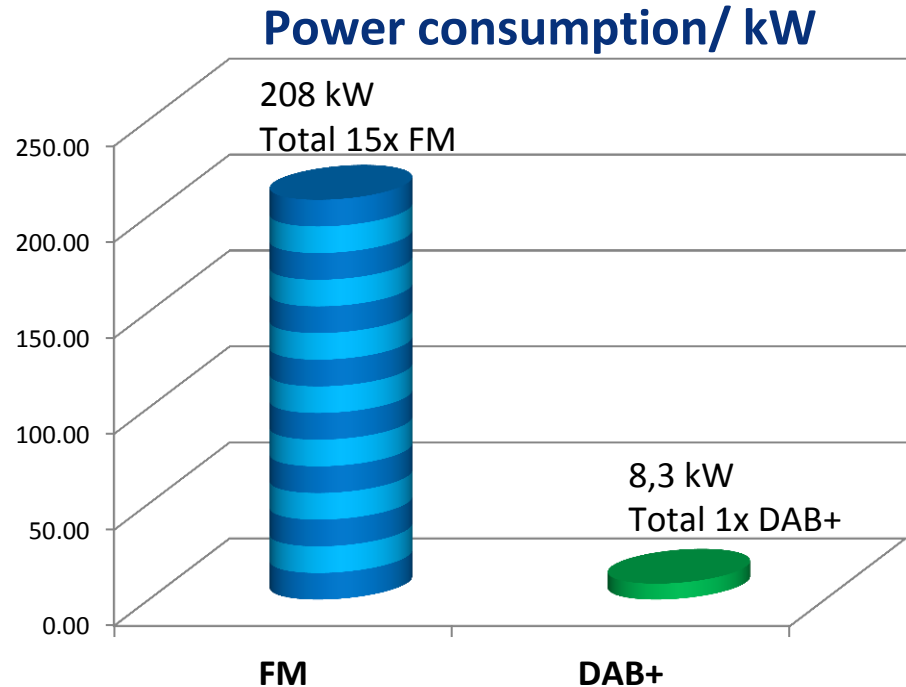

**Drastic lower energy consumption with DAB+
25x lower in the example for 15 programs compared to 10kW FM**

ENERGY COSTS DAB+ VS. FM

EXAMPLE: ENERGY BILL TRANSMITTER FOR 15 RADIO PROGRAMS

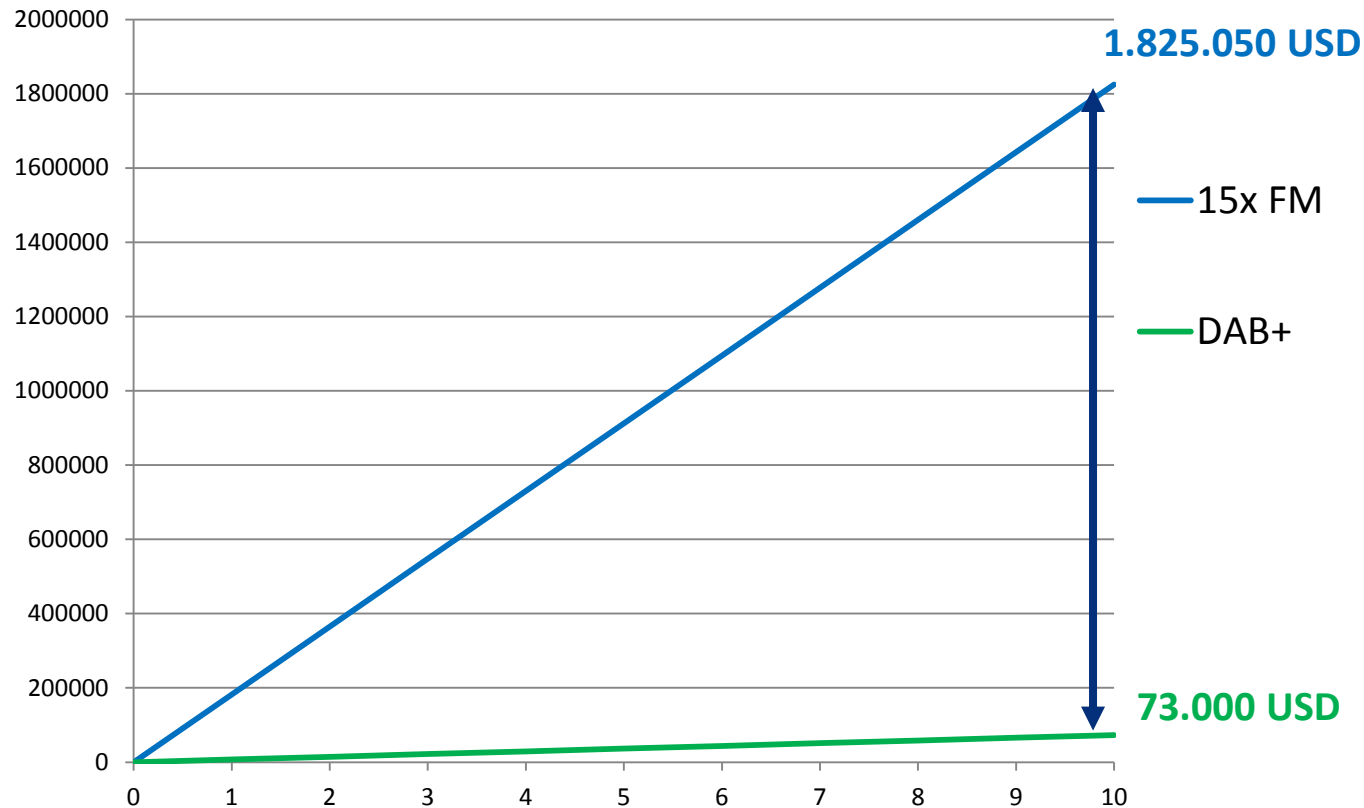

1.52 Mio USD savings with DAB+ over 10 years operation

COOLING EFFORT

ENERGY SAVING FOR ROOM COOLING DAB+ VS. FM

EXAMPLE: 15 RADIO PROGRAMS SAME COVERAGE



1x DAB+ transmitter

15 x FM transmitter

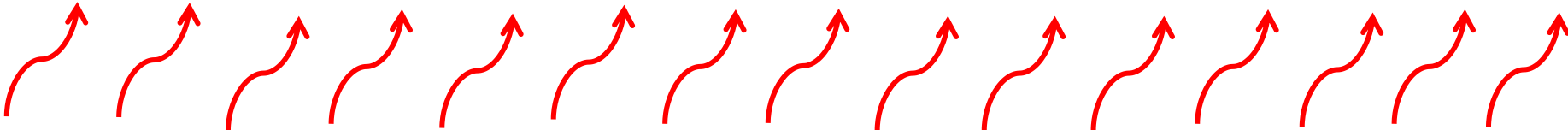

ENERGY SAVING FOR ROOM COOLING DAB+ VS. FM

EXAMPLE: 15 RADIO PROGRAMS SAME COVERAGE

	FM	DAB
TX RF Power	10 kW peak	2,5 kW rms
Power consumption	13,9 kW	8,3 kW
Dissipated Power	3,9 kW	5,8 kW
Transmitter for 15 programs	15	1
Dissipated Power for 15 Programs	58,5 kW	5,8 kW

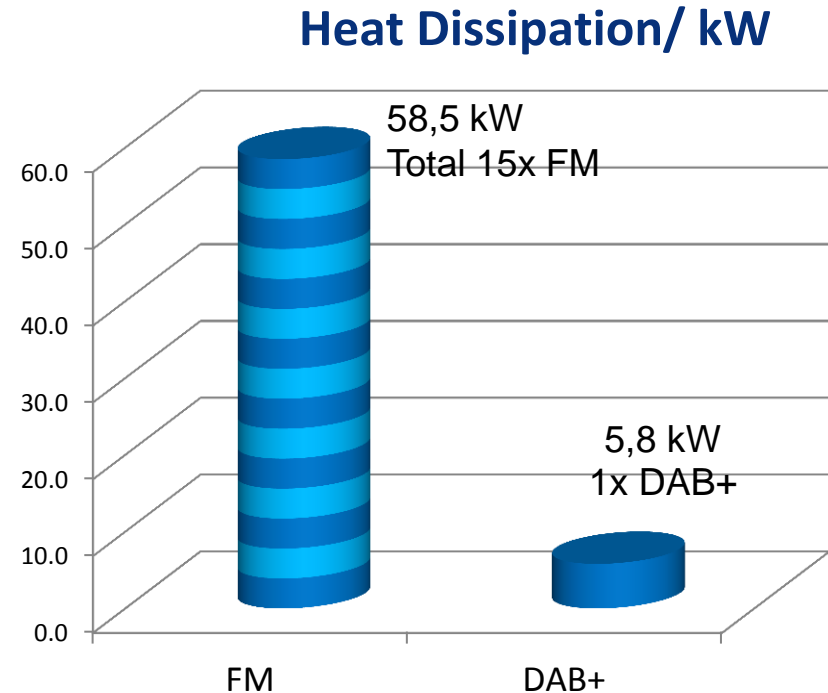

10x less heat dissipation with DAB+ compared to FM
In example of 15 Radio programs !

POWER SAVING COOLING INSTALLATIONS – AIR COOLED

- Ducted Air racks
- Evacuate the heat from the building
- Reduces Cooling costs



- Outdoor shelter
- Reduces site costs
- Fast deployment

- Both solutions reduce operating costs

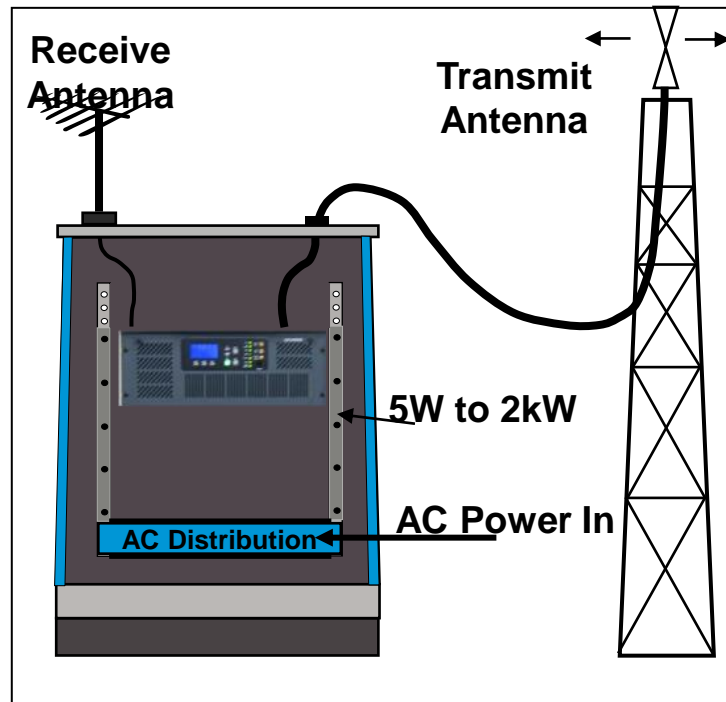

POWER SAVING COOLING INSTALLATIONS - LIQUID COOLED

further savings using transmitter with liquid cooling system

- ✓ Drastic reduced building cooling costs
- ✓ Directly evacuate heat out side of the building
- ✓ Reduced space & installation effort
- ✓ Variable speed fans and pumps
- ✓ to reduce power consumption
- ✓ Flexible hose for easy installation
- ✓ Redundant system can support multiple transmitters
- ✓ Silent, low acoustic noise
- ✓ Low maintenance effort

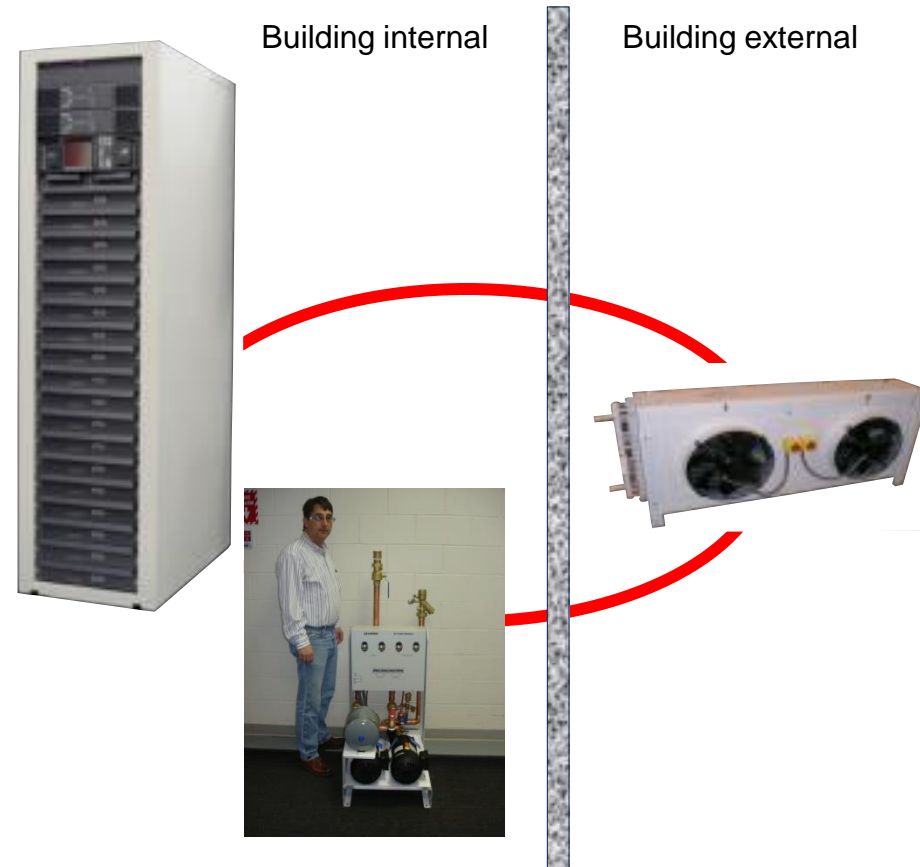

FLOOR SPACE

SPACE SAVINGS ON TRANSMISSION SITE DAB+ VS. FM

EXAMPLE: 15 RADIO PROGRAMS SAME COVERAGE

DAB

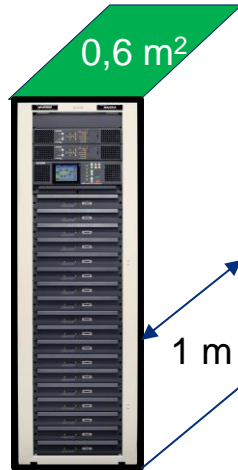

	FM	DAB
Occupied floor space 1 program	0,6 m ²	0,6 m ²
Occupied floor space 15 programs	9,0 m ²	0,6 m ²

FM

0,6 m²

9,0 m²



**15x less occupied floor space with DAB+ compared to FM
In example of 15 Radio programs !**

SAVE TOWER & ANTENNA SPACE WITH DAB+

Analog FM

- Many towers
- Interferences

DAB+

- Single Antenna
- No interferences



SERVICE & MAINTENANCE

REDUCED SERVICE & MAINTENANCE COST DAB+ VS. FM

EXAMPLE: 15 RADIO PROGRAMS



1x **DAB Transmitter**



Drastic Service cost reductions using DAB+

- reduced spare part stock
- reduced part diversity
- reduced maintenance effort

15x **FM Transmitter**



SERVICE & REPAIR OF DAB+ TRANSMITTER

LIGHT & UNIVERSAL PARTS FOR COST EFFECTIVE REPAIR & LOGISTIC

RF Pallet

identical for
Air cooled and
Liquid cooled



500 g

Power Amplifier

Air cooled

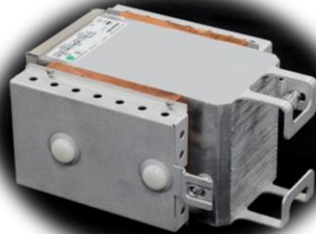

2 kg

Power Supply

Air cooled
Liquid cooled



1 kg

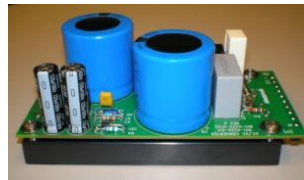

250 g

- Low spare part costs
- Low shipment costs
- Low import fee
- Easy to carry and replace

SUMMARY ECONOMICAL ADVANTAGES OF DAB+

Drastic cost reductions using DAB+ compared to FM for:

1. Equipment
2. Distribution
3. Energy
4. Cooling
5. Space
6. Service & Maintenance
7. License fee



SIMULCAST PERIOD

Simulcast period most costly for program provider

- Transition period from analog to digital for Radio longer than for TV
 - Broadcaster cannot compensate all additional costs of simulcast operation by more revenue
1. Simulcast costs are critical for acceptance & motivation of broadcaster
 2. Clear road map of analog to digital transition helps to secure planning

Thank you for your attention!

It's time for DAB+ !



DISCLAIMER

Harris Broadcast is a global supplier of hardware and software that creates, manages, transmits, distributes and monetizes video content. Headquartered in Denver, Colorado, the company is widely recognized as the preeminent brand in the broadcast communications equipment industry. Harris Broadcast's uniquely integrated digital media solutions streamline the entire content workflow from live production to transmission. With a presence in key locations around the world, Harris Broadcast supports media customers in more than 130 countries.

On February 4, 2013, The Gores Group, a Los Angeles based investment firm that acquires controlling interests in mature and growing businesses, completed the acquisition of Harris Broadcast Communications from Harris Corporation. Harris Broadcast is working with The Gores Group to drive innovation, streamline operations and enhance customer service.

This presentation and its contents may contain Harris Broadcast proprietary and confidential information. Any review, reliance, distribution, disclosure, or forwarding without expressed permission is prohibited. Harris Broadcast is an independent company not affiliated with Harris Corporation.

Copyright ©2013 Harris Broadcast. All Rights Reserved.